



S T O N E

Manufacturing Quality Products





The Kapal Difference

At Kapal, we pride ourselves on delivering timely service, exceptional craftsmanship, and top-quality manufacturing of residential and commercial kitchen cabinets and countertops throughout the Texas Rio Grande Valley. Our wide selection of wood types, stone colors, finishes, and hardware allows our customers to personalize their spaces with ease. We believe that style goes beyond aesthetics, and we're dedicated to bringing each customer's vision to life.

Kapal's journey began in 2008 with our first 10,000-square-foot cabinetry production plant. By 2011, we had expanded to 20,000 square feet, and in 2014, we entered the granite and quartz industry, reaching a total of 40,000 square feet of manufacturing facilities. In 2017, we introduced a state-of-the-art facility adjacent to our cabinetry plant, specializing in the fabrication of granite, quartz, and solid surface countertops—particularly for multifamily apartments and the hospitality industry.

In 2018, we moved our cabinetry plant to an 80,000-square-foot facility in Weslaco, TX. In 2024, we added an additional 10,000 square feet to the Weslaco facility for the storage of finished products, bringing our total manufacturing and storage space to an impressive 150,000 square feet. This growth enables us to better serve our customers with precision and efficiency.

We are proud to be among the first turnkey manufacturers to offer both cabinets and countertops with short lead times. With Kapal, you can trust that your project is in capable hands, managed by experts dedicated to professionalism and superior craftsmanship from conception to completion.



Table of Contents

Multifamily Apartments	Page 02
Hotels	Page 03
Clinics	Page 04
Cut to Size	Page 05
Granite & Quartz	Page 06
Standard Sinks	Page 07
Standard Sinks Ceramic	Page 08
3CM Quartz Conference & Dining Tables	Page 09
3CM Quartz Conference & Dining Tables Sizes	Pages 10 & 11
Granite & Quartz Products	Page 12
Kapal Stone Capacity	Page 13
Packaging	Page 14
Tips on Caring for Granite & Quartz Countertops	Page 15
Quality Control	Page 16
Why Purchase Domestic	Page 17
Kapal Added Value	Page 18
Credit Terms	Page 19

Vision

Be the best in the industry by continuously setting and meeting new goals.

Mission

With research and preparation, we plan to deliver high quality products and supplies to our customers, working diligently to meet their needs and desires.

Core Values

Treat customers with uttermost respect, honesty and humbleness, making their happiness our priority.



Multifamily Apartments



Kapal Company Group

Transform any space with our stunning countertops and sinks. We meticulously attend to every detail in our products to ensure exceptional quality and style.

Direct Importers

We are direct importers of natural stone, offering a vast selection of granite, quartz, and marble.

Turnkey Company

We provide a comprehensive solution by supplying, manufacturing, and installing your project, leaving it complete and ready for use.

Comprehensive Project Assessment

Before any job begins, we conduct a thorough study of each project to deliver high-quality results, exceptional service, short lead times, and accurate outcomes.

Precision Cutting

With 99% accuracy in every cut, we achieve perfect results while minimizing dust on the job site, allowing you to make use of your facilities more quickly.

Last Large Projects Developed

		Location:	Units:
1	Abacus Alamo Ranch Apartments	San Antonio, Tx	320
2	Saint Mary Apartments	Austin, Tx	240
3	Santal Luxury Apartments	Austin, Tx	212
4	Ambrosio Subdivision	Pflugerville, Tx	370
5	Jackson Place Apartments	Pharr, Tx	288

Hotels



Last Hotels Projects Developed

		Location:	Units:
1	Residence Inn	Corpus Christi, Tx	143
2	Townplace	Austin, Tx	110
3	Courtyard	SPI, Tx	205
4	Element Hotel	Katy, Tx	143
5	Holiday Inn	San Marcos,	80
6	Holiday Inn Express & Suites	Brenham, Tx	80

Clinics



Kapal's state-of-the-art facility is equipped to manage large projects while also providing the versatility needed for custom pieces that make your project unique. At Kapal, we go the extra mile to ensure that your project is crafted from the finest materials and installed with precision.

Last Clinics Projects Developed

		Location:
1	Dr. Alfredo V. Gonzalez Medical Facility	Pharr, Tx
2	Vela Saenz Family Dentistry	Edinburg, Tx
3	Growing Smiles Children's Dental Center	McAllen, Tx
4	Little Heroes Pediatric Dentistry	San Juan, Tx
5	Pulmonary & Sleep Center of the Valley	McAllen, Tx
6	McAllen Oncology P. A.	McAllen, Tx

*“Great people doing high quality and innovative products.
Excellent service.”*

Marco Antonio Castilla
Google Review

Cut to Size One Kitchen at a Time

As a full-service company, we cater to fabricator OEMs with cutting, edging, and polishing of **Quartz**, **Granite**, and **Dekton** in our large, state-of-the-art factory. Our efficient processes minimize lead times and reduce dust at the job site.

How does it work?

1

Select Your Material:

Choose from our wide variety of high-quality options.

2

Measure for Precision:

Your preferred fabricator should measure the desired countertop space to create accurate shop drawings.

3

Begin Manufacturing:

Once we receive the approved shop drawings, along with all measurements and specifications, we will commence the manufacturing process.

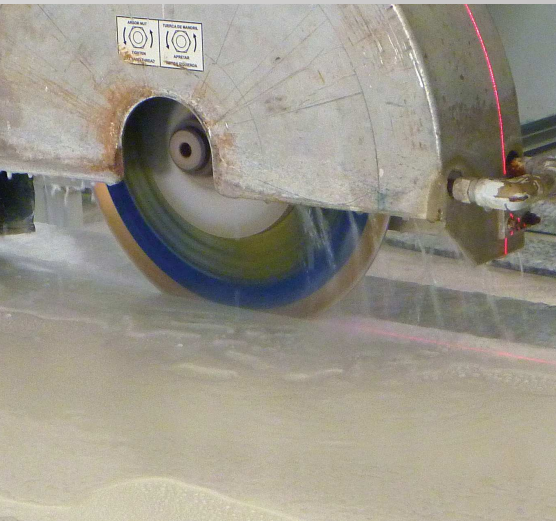

4

Quick Turnaround:

Small projects typically have a turnaround time of 3-7 days after receiving the shop drawings.

5

Final Pick Up:

Once the countertop is ready, your fabricator can pick up the finished product.

6

Installation Ready:

Your fabricator is prepared to begin a hazard-free installation of a cut-to-size countertop.

*We offer delivery.

*Lead Time: 3 - 7 days if material in stock.

*For large projects, please contact a sales representative.

Granite & Quartz Usually In Stock

Comodity Granite Colors: 2cm & 3cm



Santa Cecilia



Ornamental



Fiorito



White Dallas



Venetian Ice



Venetian Gold



Caledonia



Ubatuba



Kashmir White

Quartz Entry Level I Colors: 2cm

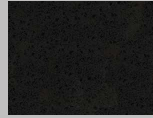
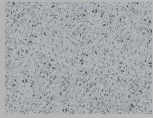

Eternal collection: 2cm Usually In Stock from SILESTONE



Calacatta Gold



Statuario



Pearl Jasmine



Serena

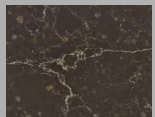

Emperador



Charcoal Soapstone

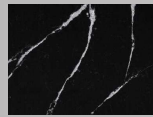

Marquina



*Colors are for reference only.

*The colors above are typically in stock, but we also carry a large variety of other colors.

Standard Sinks Usually In Stock

Kitchen Handmade Sinks 18" GA & 16" GA

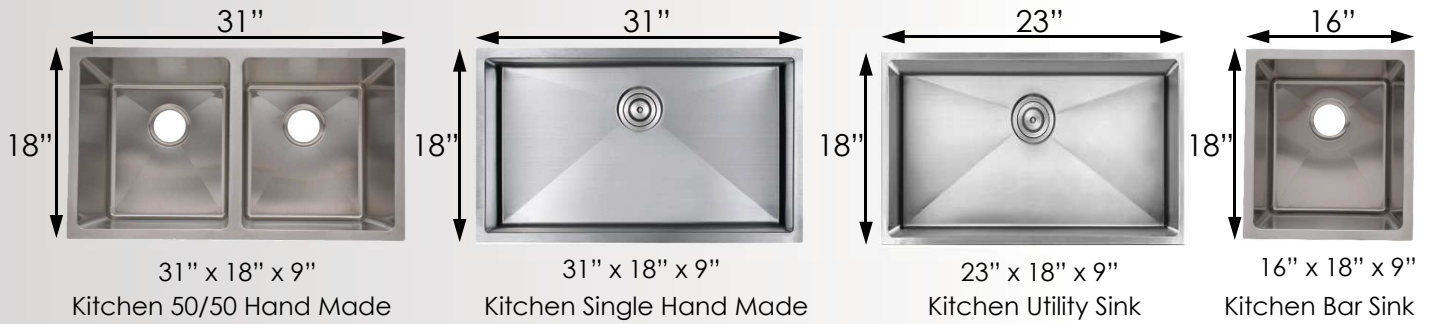

Kitchen Standard Sinks 18" GA

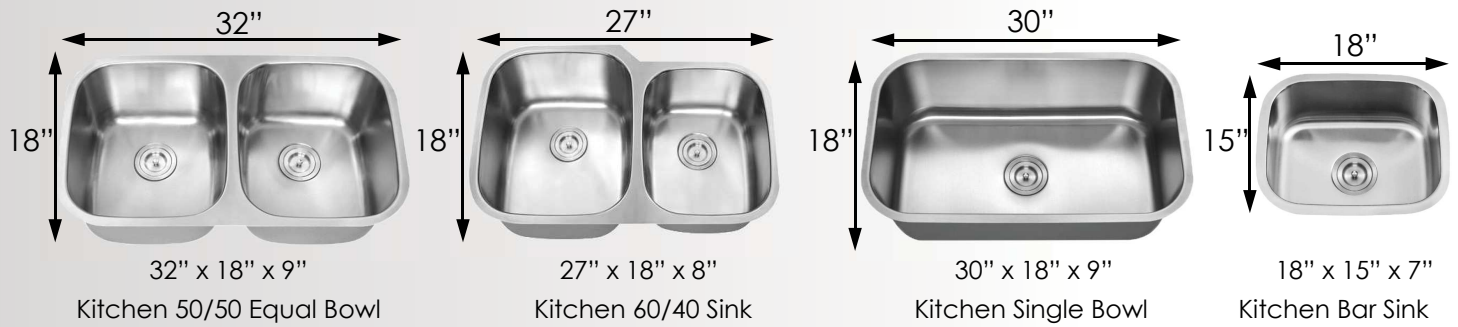

Under-mount Sink Installation

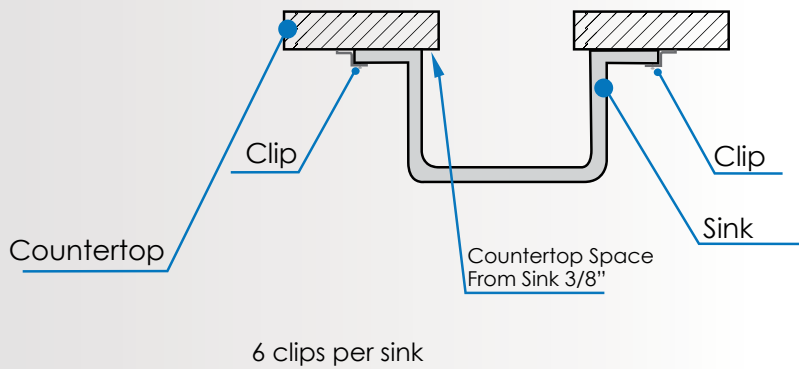

Sink Measurements are Approximate

*Dimensions are for reference only, not for cutting purposes.
*Photo is for reference only; the final product may vary.

Standard Sinks

Usually In Stock

Ceramics Bath Sinks

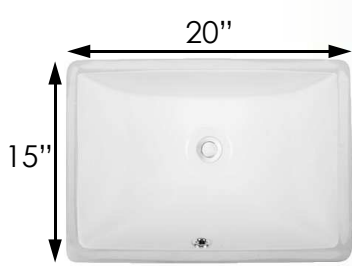

20" x 15" x 7"

Ceramic Rectangular Large

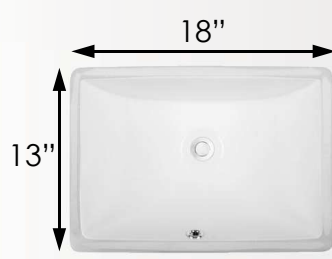

18" x 13" x 7"

Rectangular Easy Wall Small

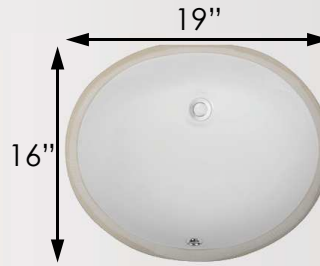

19" x 16" x 8"

Ceramic Large Oval

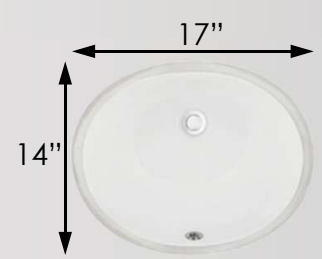

17" x 14" x 7"

Ceramic Small Oval

Ceramic Drop In Bath Sink

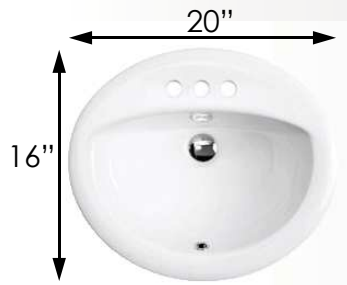

20" x 16" x 8"

Ceramic Square Drop In Bath Sink

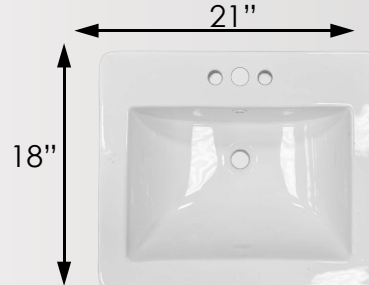

21" x 18" x 6"

Under-mount ceramic sink

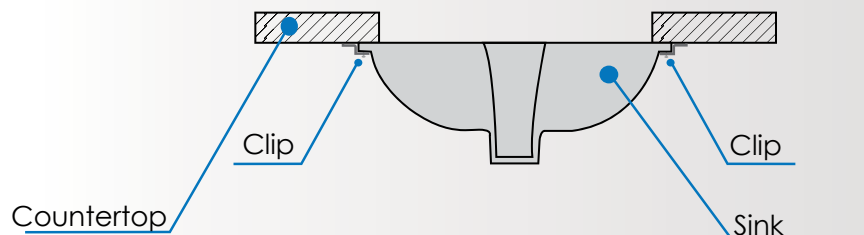

2 clips per sink

*Dimensions are for reference only, not for cutting purposes.

*Photo is for reference only; the final product may vary.

956-464-3311

3CM Quartz Conference & Dining Tables



Table Top shape:

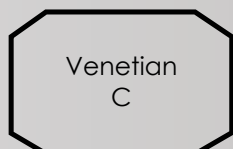
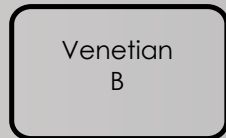
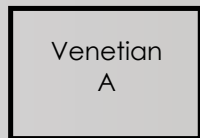

Table Bases:



Wood



Metal



Quartz

Profiles:



Eased Edge



Bevel

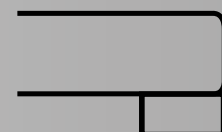

Lamination

3CM Quartz Conference & Dining Tables Sizes

VENETIAN

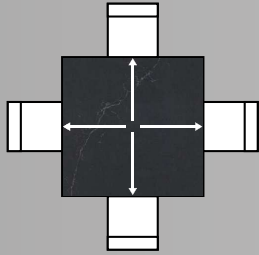

Size: 36" x 36"
Seats: 4

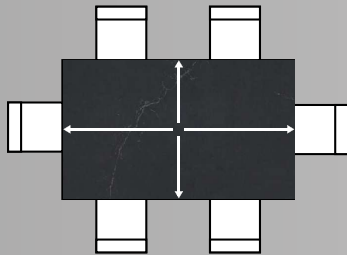

Size: 59" x 36"
Seats: 6

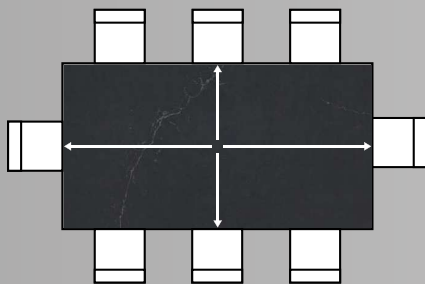

Size: 79" x 43"
Seats: 8

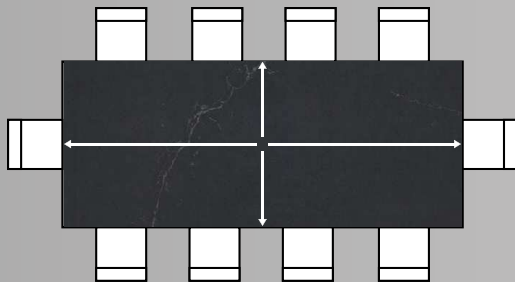

Size: 102" x 43"
Seats: 10

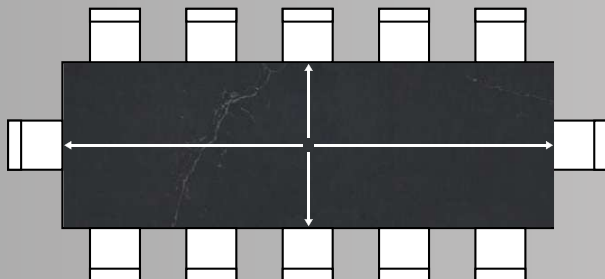

Size: 125" x 43"
Seats: 12

MILAN









*Available to customize your own size

956-464-3311

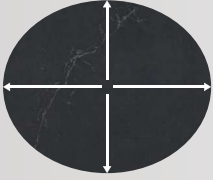
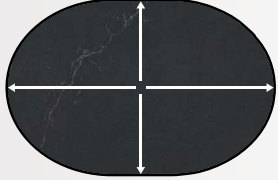
Standard dimensions

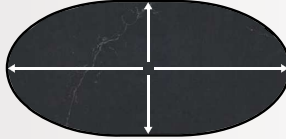
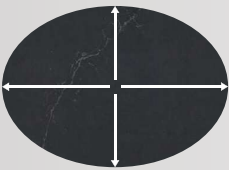
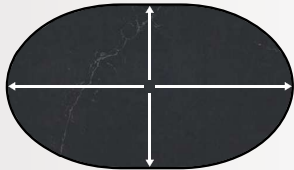
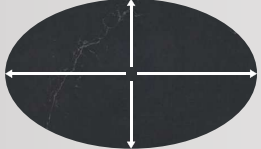
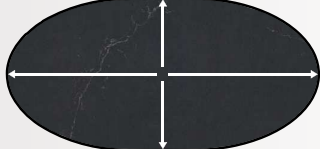
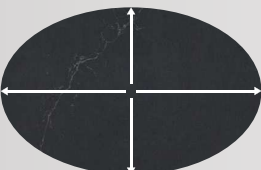
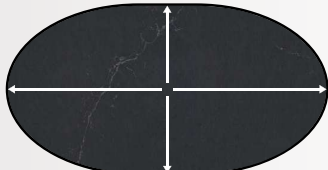
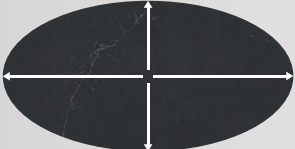
Seats: 8-15

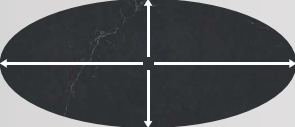
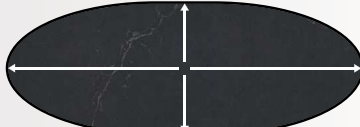
FLORENCE

	Size: 60" x 72"		Size: 60" x 92"
	Size: 46" x 77"		Size: 46" x 97"
	Size: 56" x 78"		Size: 56" x 98"
	Size: 52" x 87"		Size: 52" x 107"
	Size: 58" x 90"		Size: 58" x 110"
	Size: 52" x 100"		Size: 52" x 120"
	Size: 45" x 102"		Size: 45" x 122"
	Size: 42" x 106"		Size: 42" x 126"

Granite & Quartz Products

Introducing Kapal's new line of granite and quartz products—elegant, durable, and functional. Perfect for offices, households, and kitchens, these products combine style and practicality.



Products we offer:

- Plantpots
- Cutting boards
- Patio tables
- Business cards holders
- Window sills
- Sculpture base



Plant Capacity

Kapal operates an advanced manufacturing facility in the state of Texas, utilizing world-class equipment to ensure your product meets the highest standards of quality, precision, and performance. Our capabilities are continuously growing to keep pace with the ever-evolving demands of the marketplace.

We offer a wide range of services, from simple component manufacturing and assembly to full project capabilities, including concept to completion, manufacturing, inventory stocking, and supply.

Production Installed Capacity:

- 5,000 sq ft per week



Benefits



Shorter Lead Times

Being based in the U.S. allows us to deliver faster service without compromising on quality.



All-In-One Company

We offer manufacturing, assembly, material supply, delivery, and installation services, providing a comprehensive solution for all your projects.



Competitive Prices

By manufacturing our own products and optimizing materials and production times, we can offer better pricing.



High-Quality Products

We source the best materials and use the latest technology to ensure superior results in every project.



Innovation & Design

We constantly seek the latest trends and most practical solutions to help you optimize your spaces.



Safety & Quality Control

Our commitment is to deliver high-quality products that are safe and properly assembled for customer use.

Packaging

2 types of Packaging

Wood Crate



Wood A Frame



- All crates are verified and calibrated to ensure they do not exceed 2,500 lbs.
- Each crate is tagged with its estimated weight.
- Crates shipped on a flatbed are wrapped with stretch film for added protection.
- All A-frames are labeled with their contents.
- A-frames are calibrated to ensure they do not exceed 3,000 lbs. (1,500 lbs. per side).



Tips on Caring for Granite & Quartz Countertops

When it comes to cleaning your kitchen counters, one method does not fit all. Here's how to keep your granite and quartz countertops in top shape.

Granite

■ Clean Daily:

Wipe down your granite countertops with a damp cloth and a few drops of dishwashing soap. Rinse with clean water and dry with a soft cloth. There's no need to use chemicals or specialty cleaners every day.

■ Seal Annually:

Apply a granite sealer every 12 months to protect against stains and germs. Sealing helps prevent damage from settling into the pores and natural cracks of the stone.

■ Avoid Harsh Chemicals:

Do not use vinegar, lemon juice, or harsh cleaners, as well as abrasive materials, which can damage the surface.

Quartz

■ Cleaning Quartz:

The best way to clean quartz countertops is with mild dish soap, water, and a soft, non-abrasive cloth. While quartz is stain-resistant, it is not completely stain-proof, so it's important to clean up spills and messes as soon as possible.

■ Heat Resistance:

Quartz is burn-resistant under normal conditions, but it's still best to use a trivet or hot pad beneath heat-generating items such as hot pans or crockpots. Be cautious of sudden temperature changes, especially near edges or cutouts, as this can cause cracks in the countertop.

■ Tough Cleaning:

For tougher stains like hardened food or dried grease, use a plastic putty knife to gently scrape the area before wiping it down. Avoid using abrasive scouring pads, which can scratch the surface over time. A mild degreaser labeled safe for quartz can help break down hardened grease. Do not use bleach-based cleaners, as they can damage the surface.

Sources:

Caesarstone: Care Guide
MSI: Care & Use
LX Hausys: Care & Maintenance

*For additional information, please contact a professional countertop maintenance company.

Quality Control

1. Adhesive Testing: Prior to application, a test is conducted when using adhesive.
2. Joint Visibility: If a joint is visible from a distance greater than 4 feet, it will be verified and approved by the client.
3. Recommended Adhesive: The adhesive used will be that recommended by the quartz brand.
4. Chip Repairs: Patched chips will not exceed 1/8 inch in size.
5. Measurement Tolerance: The acceptable tolerance in measurements is +1/16 inch to -1/8 inch.
6. Finished Goods Audit: We conduct audits of finished goods.
7. Incoming Material Inspection: We inspect incoming materials and submittals, which are secured under lock and key.
8. Cut-Out Tolerance: Cut-out tolerances are set at +1/8 inch to -1/8 inch.
9. Center Cut-Out Tolerance: The tolerance for the center of cut-outs is +1/8 inch to -1/8 inch.

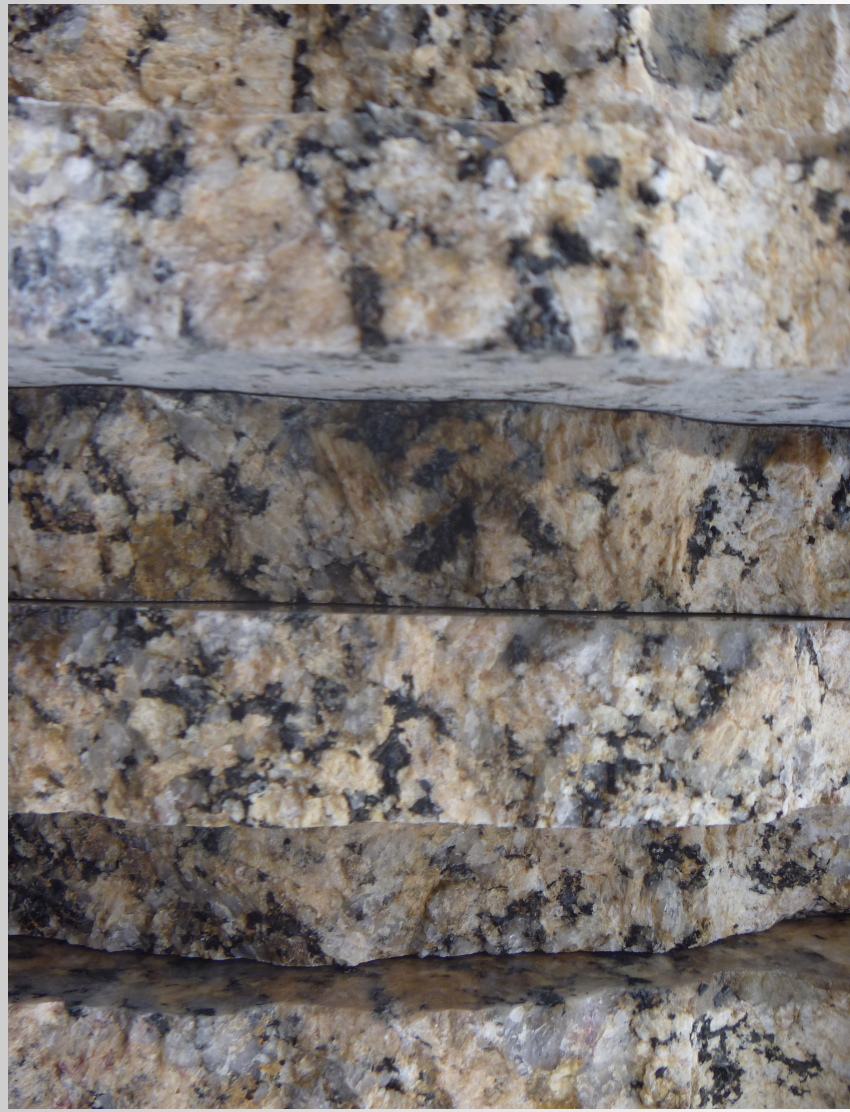

Why Purchase Domestic?

Let's Eliminate Hidden Costs!

- **Faster Lead Times:** Get your materials quicker with no delays.
- **Better Payment Terms:** Enjoy more flexible payment options.
- **Flexibility with Dimension Changes:** Easily accommodate any adjustments needed.
- **No Inventory Sitting at Job Site:** Order when you're ready to install—no storage costs.
- **Change Order Friendly:** We can accommodate changes during the project without hassle.
- **No Leftover Material:** Order exactly what you need, reducing waste and extra costs.
- **Faster Replacements/Reworks:** Quick turnaround times for any issues.

If these advantages don't translate into savings for your project, it's better to

"Keep the money at home."

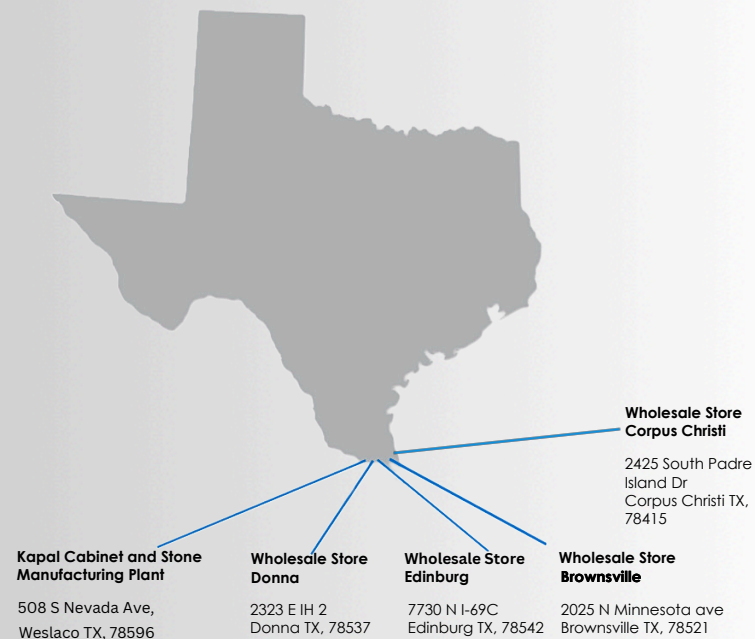

Kapal Added Value

- **Corner Protection Packaging:** All cabinets come securely packaged with corner protection to prevent damage during transport. **(A)**
- **Complete Installation Accessories Included:** Every order includes all necessary accessories for installation—shims, screws, cap screws, silicone, and touch-up crayons. **(B)**
- **Dust-Free Installation:** Microwave exhaust ducts and island electrical receptacle cutouts are pre-made in the factory, eliminating dust and mess at the job site. **(C)**
- **Pre-Drilled Cabinets:** All cabinets are pre-drilled for easy attachment to adjacent units, ensuring faster installation and consistent screw placement. **(D)**
- **Standardized Cabinet Backing:** All cabinet backs are uniform in thickness (1/2", 5/8", or 3/4"), ensuring consistency across all units. **(E)**
- **Plywood Drawer Bottoms:** Drawer bottoms are made from high-quality plywood in 1/2", 5/8", or 3/4" thicknesses. **(E)**
- **High-Quality Boards:** We use either melamine or plywood for boards, eliminating the use of wrap paper (unless specified). **(F)**
- **Property Identification:** Each cabinet is clearly labeled with its position in the room and building, along with the job name for easy identification. **(G)**
- **Barcode Scanning:** Shipments are loaded and scanned with barcodes to ensure complete and accurate deliveries. **(G)**
- **No Cutting on Site:** No Quartz or Granite cutting is done at the job site, ensuring no dust or mess at your location.

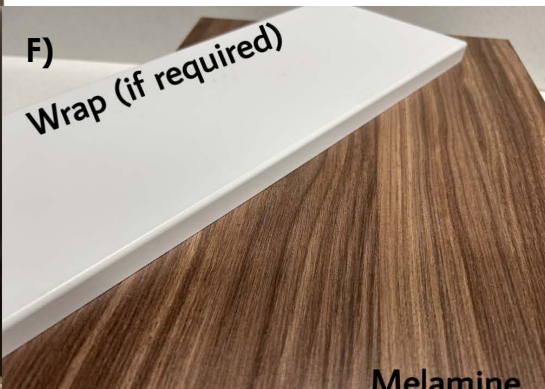
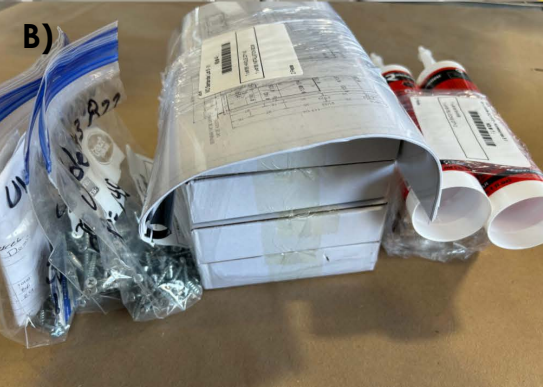

Credit Terms

Kapal offers credit based on the purchase history of the past 24 months.

- Credit Amount: Customers are eligible for credit equal to 5% of the sales invoices from the past 24 months, with terms of Net 30.
- Credit Usage: The credit can be applied as a down payment, retainage, or final payment, with the same Net 30 terms.
- Payments:
 - For Common Material Minimum Downpayment of 30% at Initial.
 - For Special Material (Cannot be used w/ another customer): Minimum Downpayment of 50% at Initial.
 - Rest of Payment of Merchandise Value before Delivery for Each Shipment: The product will be manufactured in advance, one or two weeks before the delivery date requested by the customer. However, customers cannot receive the merchandise by the time requested by them, the product will be held for 30 days, however payment must be submitted for the partial of the manufactured items requested with proof of merchandise manufacture if needed.



UNIQUE STYLES, GREAT QUALITY



**Wholesale Store
Donna**
2505 E IH 2
Donna TX, 78537

**Wholesale Store
Edinburg**
7730 N I-69C
Edinburg TX, 78542

**Wholesale Store
Brownsville**
2025 N Minnesota
ave Brownsville TX,
78521

**Wholesale Store
Corpus Christi**
2425 South Padre
Island Dr Corpus Christi
TX, 78415

**Kapal Cabinet and Stone
Manufacturing Plant**
508 S Nevada Ave Weslaco
TX, 78596

 **Kapal Industries**

November 2024